

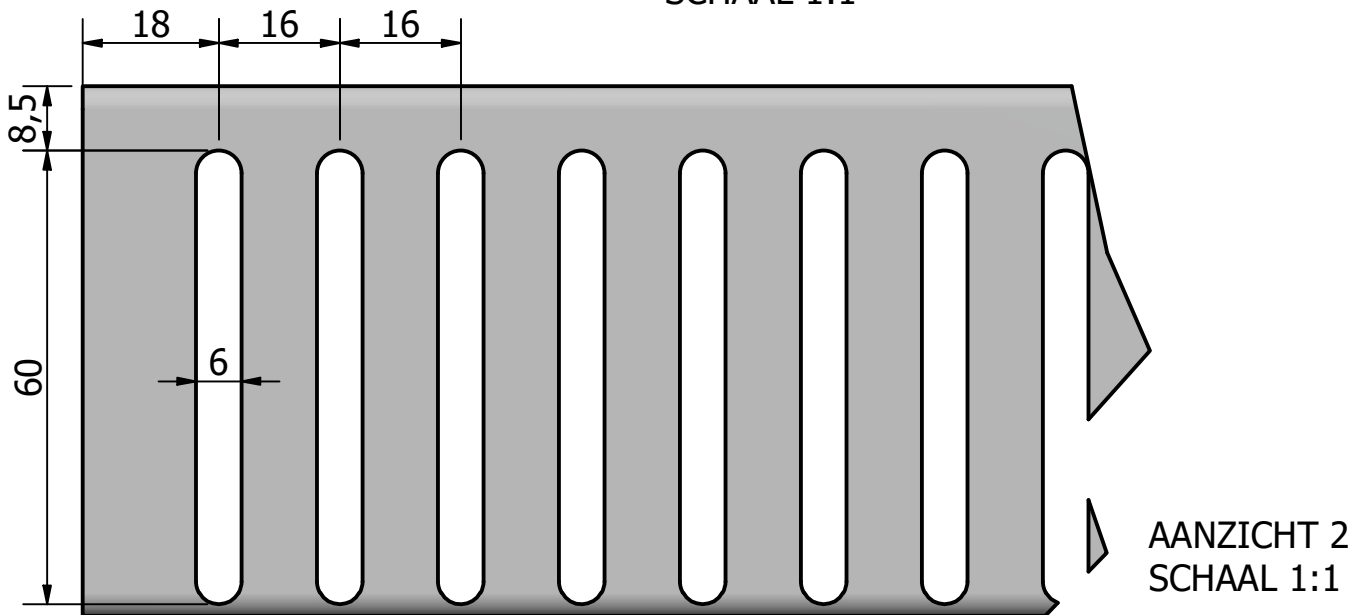

niet aangeduid=R0.2 ▲ =R0.3 △ =R0.5 ■ =R0.8 □ =R1 ● =R1.5 ○ =R2 ∟ =30° ▲ =45° ∇ =0.3x90° ∇ =0.3x90° ID = 0.3x90°

S = snijpunt, overige maten over de eventuele afrondingen. R = volle radius. Niet aangegeven wanddikte: 1.1 mm

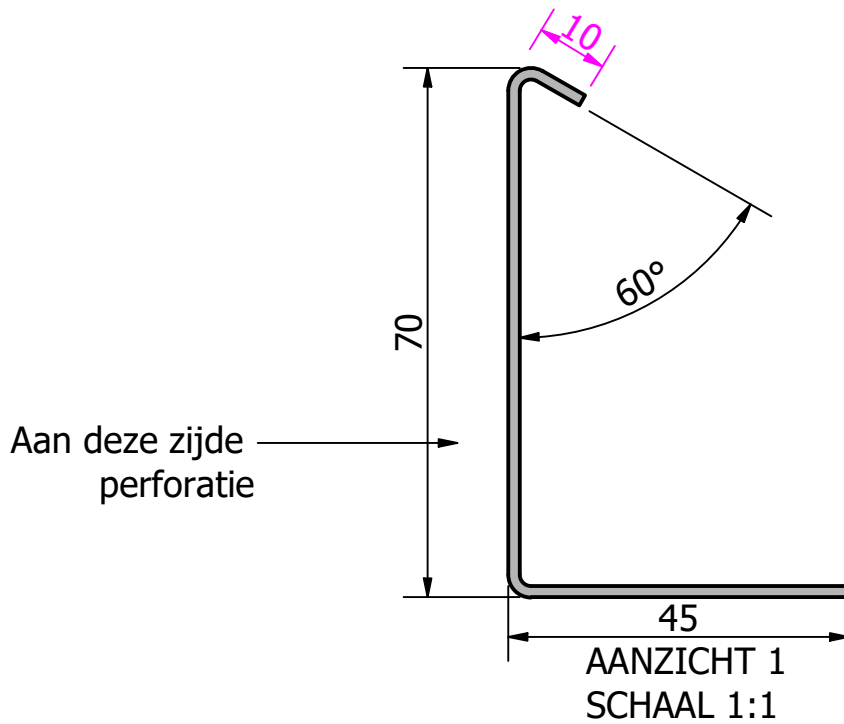

Tolerance according to EN-12020-2
Materiaal EN-AW-6060 Temper T6

Projectnaam:

Projectnr./Ordernr.:	Getekend:	Datum: 5-4-2022	Toleranties vlgs NEN-ISO 2768-mK tenzij anders aangegeven		
	Gecontroleerd:	Datum:	Geometrische toleranties vlgs ISO 8015 tenzij anders aangegeven		
	Omschrijving:		AM- Projectie	Ra=6.3	
	Tekening nr.:	Revisie:	Formaat:	Schaal:	Blad:
	158200	A	A4	1:1 Eenheid in mm	1 / 1
All rights reserved. Reproduction without written permission, in any shape or form is strictly prohibited.					